



ADTECH
Analog-Digital Technology, Inc.

300 Series Three-Wire Field Selectable Wide Ranging Transmitters Guide



Features

- **Types of Inputs:** AC I/V (TRMS or average); frequency, millivolts, potentiometer, RTD, DC I/V, T/C.
- **No Interaction:** Zero and span controls
- **Elevation/Suppression:** Up to 100% of range
- **Power Range:** 15 to 42 VDC, 28 mA typical
- **RFI-Resistant**
- **Temperature Coefficients:**
Zero = $\pm 0.007\%/^{\circ}\text{C}$ of span—typical
Span = $\pm 0.008\%/^{\circ}\text{C}$ of span—typical
- **Repeatability:** $\pm 0.002\%$ typical
- **Bandwidth:** (-3 db): 3.2 Hz typical
- **Isolation:** 1000 VDC or 600 VAC
- **Power Supply Effect:** $\pm 0.005\%$ of span
- **Response Time:** 110 milliseconds typical
- **Reverse Polarity Protection**

Typical Applications

Measurement of:

- Temperature
- Flow
- Speed
- Position
- Displacement
- Rotation
- AC Current
- AC Voltage
- DC Signals

AC Input ACT 340 (Isolated)

Input/Output

Input Signals

AC Current: Any 0-1 to 0-5 amps AC, burden less than 0.5 VA (Selectable average or true RMS responding)

AC Voltage: Any 0-0.25 to 0-250 VAC, burden less than 0.5 VA (Selectable average or true RMS responding) (4 major ranges 0.25, 2.5, 25, 250)

Zero Adjustment: ±5% nominal of span

Course Span Adjustment: 100% of a major range (voltage only)

Fine Span Adjustment: ±5% nominal of major range (±1 Amp for current input)

Input Frequency Range: 25-1,000 Hz

Input Overload Capability: 200% continuous

Output Signals: 4-20 mA DC; 0-20 mA DC; 0-10 mA DC; 0-1 mA DC; 1-5 VDC; 0-5 VDC; 0-10 VDC

Output Loop Drive Capability:

$$R(\text{ohm}) = \frac{(V \text{ supply}-5)1,000}{I \text{ out max. mA}}$$

V Supply: 15 to 42 VDC

I out	4-20 mA or 0-20 mA			
V supply	15	24	36	42
R(ohms)	500	950	1550	1850

Performance

Calibrated Accuracy: ±0.25%

Independent Linearity: ±0.15% maximum, ±0.06% typical

Repeatability: ±0.005% max., ±0.002% typ.

Zero TC: ±0.01% of span max/°C

Span TC: ±0.02% of span max/°C

Load Effect: ±0.005% zero to full load

Output Ripple: 10 mV P/P maximum

Response Time: 350 milliseconds (10 to 90% step response) average responding

Bandwidth: (-3 db): 1 Hz

Temperature Range:

-25° to 185°F (-31° to 85°C) operating;

-40° to 200°F (-40° to 93°C) storage

Power Supply Effect: ±0.005% of span, max.

Isolation: Input/output/case: 1000 VDC or 600 VAC

Note: All accuracies are given as a % of span.

Power

15 to 42 VDC: 28 mA typical; 33 mA maximum

Mechanical

Electrical Classification: General purpose

Connection: Screw, compression type, accepts up to 14 AWG

Controls: One 16-position rotary switch for course span; two multiturn potentiometers for fine zero and span control, jumpers for measurement response type TRMS or average and for input ranges and output selection

Mounting: DIN rails, Surface, snap-track, or NEMA 4 or 7

Weight: Net Unit: 4 oz. (115 grams);

Shipping: Nominal 7 oz. (200 grams)

Options

H 15 D, H 25 – H 30 Mounting
LPI 40 D Loop powered indicator

Frequency Input FDT 350 (Isolated)

Input/Output

Input Signals

Voltage (Amplitude): 10 mV-100 Vrms (0-5 kHz); 50 mV to 50 Vrms (5 kHz to 30 kHz)

Contact: Dry, 2 mA @ 24 VAC rating

Frequency Range: 0-30 Hz to 0-30 kHz full scale

Major Range Switch: Provides 11 discrete ranges with the zero control adjustable 10% of output and span control adjustable from 50% to 100% of the major range selected

Output Signals: 4-20 mA DC; 0-20 mA DC; 0-10 mA DC; 0-1 mA DC; 1-5 VDC; 0-5 VDC; 0-10 VDC

Output Loop Drive Capability:

$$R(\text{ohm}) = \frac{(V \text{ supply}-5)1,000}{I \text{ out max. mA}}$$

V Supply: 15 to 42 VDC

I out	4-20 mA or 0-20 mA			
V supply	15	24	36	42
R(ohms)	500	950	1550	1850

Performance

Calibrated Accuracy: ±0.1%

Independent Linearity: ±0.02% max.; ±0.01% typical

Repeatability: ±0.005% max., ±0.002% typ.

Zero TC: ±0.01% of span max/°C

Span TC: ±0.01% of span max/°C

Load Effect: ±0.005% zero to full load

Output Ripple: 10 mV P/P maximum

Response Time: 350 milliseconds (10 to 90% step response)

Bandwidth: (-3 db): 1 Hz

Temperature Range:

-25° to 185°F (-31° to 85°C) operating;

-40° to 200°F (-40° to 93°C) storage

Power Supply Effect: ±0.005% of span, max.

Isolation: Input/output/case: 1000 VDC or 600 VAC

Note: All accuracies are given as a % of span.

Power

15 to 42 VDC: 28 mA typical; 33 mA maximum

Mechanical

Electrical Classification: General purpose

Connection: Screw, compression type, accepts up to 14 AWG

Controls: One 16 position rotary switch for major range; four multiturn potentiometers for zero, span, hysteresis and sensitivity and jumpers for input selection

Mounting: DIN rails, Surface, snap-track, or NEMA 4 or 7

Weight: Net Unit: 4 oz. (115 grams);

Shipping: Nominal 7 oz. (200 grams)

Options

H 15 D, H 25 – H 30 Mounting
LPI 40 D Loop powered indicator

MV Input MVT 306 (Non-Isolated)

Input/Output

Input Signals

0.5 mV to 100 mV span (Z in greater than 10 megohms)

Zero Suppression: Up to 100% of the major range selected in 16 divisions of the coarse zero adjustment switch

Span: From 0.5 mV to 100 mV full scale switch selectable. The coarse span switch adds 16 divisions to each major range.

Output Signals: 4-20 mA DC; 0-20 mA DC; 0-10 mA DC; 0-1 mA DC; 1-5 VDC; 0-5 VDC; 0-10 VDC

Output Loop Drive Capability:

$$R(\text{ohm}) = \frac{(V \text{ supply}-5)1,000}{I \text{ out max. mA}}$$

V Supply: 15 to 42 VDC

I out	4-20 mA or 0-20 mA			
V supply	15	24	36	42
R(ohms)	500	950	1550	1850

Performance

Calibrated Accuracy: ±0.1%

Independent Linearity: ±0.01% maximum, ±0.006% typical (14-bit digital linearity)

Repeatability: ±0.005% max., ±0.002% typ.

Zero TC: $\pm \left(\frac{0.025}{\text{input span (mV)}} + 0.005 \right)$ % of span max./°C

Span TC: ±0.008% of span max/°C

Load Effect: ±0.005% zero to full load

Output Ripple: 10 mV P/P maximum

Response Time: 110 milliseconds (10 to 90% step response)

Bandwidth: (-3 db): 3.2 Hz

Temperature Range:

-25° to 185°F (-31° to 85°C) operating;

-40° to 200°F (-40° to 93°C) storage

Power Supply Effect: ±0.005% of span, max.

Note: All accuracies are given as a % of span.

Power

15 to 42 VDC: 28 mA typical; 33 mA maximum

Mechanical

Electrical Classification: General purpose

Connection: Screw, compression type, accepts up to 14 AWG

Controls: Two 16 position rotary switches for coarse zero and span control; two multiturn potentiometers for fine zero, span control and jumpers for major range; zero elevation and output selection

Mounting: DIN rails, Surface, snap-track, or NEMA 4 or 7

Weight: Net Unit: 4 oz. (115 grams);

Shipping: Nominal 7 oz. (200 grams)

Options

H 15 D, H 25 – H 30 Mounting
LPI 40 D Loop powered indicator

MV Input MVT 326 (Isolated)

Input/Output

Input Signals

0.5 mV to 100 mV span (Z in greater than 10 megohms)

Zero Suppression: Up to 100% of the major range selected in 16 divisions of the coarse zero adjustment switch

Span: From 0.5 mV to 100 mV full scale switch selectable. The coarse span switch adds 16 divisions to each major range.

Output Signals: 4-20 mA DC; 0-20 mA DC; 0-10 mA DC; 0-1 mA DC; 1-5 VDC; 0-5 VDC; 0-10 VDC

Output Loop Drive Capability:

$$R(\text{ohm}) = \frac{(V \text{ supply}-5)1,000}{I \text{ out max. mA}}$$

V Supply: 15 to 42 VDC

I out	4-20 mA or 0-20 mA			
V supply	15	24	36	42
R(ohms)	500	950	1550	1850

Performance

Calibrated Accuracy: ±0.1%

Independent Linearity: ±0.01% maximum, ±0.006% typical (14-bit digital linearity)

Repeatability: ±0.005% max., ±0.002% typ.

$$\text{Zero TC: } \left(\frac{0.025}{\text{input span (mV)}} + 0.005 \right) \% \text{ of span max. } ^\circ\text{C}$$

Span TC: ±0.008% of span max/°C

Load Effect: ±0.005% zero to full load

Output Ripple: 10 mV P/P maximum

Response Time: 110 milliseconds (10 to 90% step response)

Bandwidth: (-3 db): 3.2 Hz

Temperature Range:

-25° to 185°F (-31° to 85°C) operating;

-40° to 200°F (-40° to 93°C) storage

Power Supply Effect: ±0.005% of span, max.

Isolation: Input/output/case: 1000 VDC, or 600 VAC

Note: All accuracies are given as a % of span.

Power

15 to 42 VDC: 28 mA typical; 33 mA maximum

Mechanical

Electrical Classification: General purpose

Connection: Screw, compression type, accepts up to 14 AWG

Controls: Two 16 position rotary switches for coarse zero and span control; two multiturn potentiometers for fine zero and span control and jumpers for major range; zero elevation and output selection

Mounting: DIN rails, Surface, snap-track, or NEMA 4 or 7

Weight: Net Unit: 4 oz. (115 grams);

Shipping: Nominal 7 oz. (200 grams)

Options

H 15 D, H 25 – H 30 Mounting
LPI 40 D Loop powered indicator

Potentiometer Input PTT 373 (Non-Isolated)

Input/Output

Input Signals

Potentiometers/Slidewire Sensors: 3 Wire

50 ohm to 100 k ohm Resistance Spans

Standard

Zero Suppression: Up to 100% of the potentiometer rotation selected in 16 divisions of the coarse zero adjustment switch.

Span: From 0-100% full scale switch selectable. The coarse span switch adds 16 range divisions.

Output Signal: 4-20 mA DC; 0-20 mA DC; 0-10 mA DC; 0-1 mA DC; 1-5 VDC; 0-5 VDC; 0-10 VDC

Output Loop Drive Capability:

$$R(\text{ohm}) = \frac{(V \text{ supply}-5)1,000}{I \text{ out max. mA}}$$

V Supply: 15 to 42 VDC

I out	4-20 mA or 0-20 mA			
V supply	15	24	36	42
R(ohms)	500	950	1550	1850

Performance

Calibrated Accuracy: ±0.1%

Independent Linearity: ±0.01% maximum, ±0.006% typical (14-bit digital linearity)

Repeatability: ±0.005% max., ±0.002% typ.

Zero TC: ±0.007% of span max/°C

Span TC: ±0.010% of span max/°C

Load Effect: ±0.005% zero to full load

Output Ripple: 10 mV P/P maximum

Response Time: 110 milliseconds (10 to 90% step response)

Bandwidth: (-3 db): 3.2 Hz

Temperature Range:

-25° to 185°F (-31° to 85°C) operating;

-40° to 200°F (-40° to 93°C) storage

Power Supply Effect: ±0.005% of span, max.

Note: All accuracies are given as a % of span.

Power

15 to 42 VDC: 28 mA typical; 33 mA maximum

Mechanical

Electrical Classification: General purpose

Connection: Screw, compression type, accepts up to 14 AWG

Controls: Two 16 position rotary switches for coarse zero and span control; two multiturn potentiometers for fine zero and span control and jumpers for output selection

Mounting: DIN rails, Surface, snap-track, or NEMA 4 or 7

Weight: Net Unit: 4 oz. (115 grams);

Shipping: Nominal 7 oz. (200 grams)

Options

H 15 D, H 25 – H 30 Mounting
LPI 40 D Loop powered indicator

RTD Input RBT 374 (Non-Isolated)

Input/Output

Input Signals

Resistance Bulb Sensor: 2,3, or 4 wire types

1 to 400 ohm Resistance Spans: Standard

Zero Suppression: Up to 100% of the major range selected in 16 divisions of the coarse zero adjustment switch.

Span: From 0-100% full scale switch selectable. The coarse span switch adds 16 divisions to each major range.

Lead Compensation: 1% maximum error, of differential lead resistance.

Output Signals: 4-20 mA DC; 0-20 mA DC; 0-10 mA DC; 0-1 mA DC; 1-5 VDC; 0-5 VDC; 0-10 VDC

Output Loop Drive Capability:

$$R(\text{ohm}) = \frac{(V \text{ supply}-5)1,000}{I \text{ out max. mA}}$$

V Supply: 15 to 42 VDC

I out	4-20 mA or 0-20 mA			
V supply	15	24	36	42
R(ohms)	500	950	1550	1850

Performance

Calibrated Accuracy: ±0.1%

Independent Linearity: ±0.025% max., ±0.01% typical

Conformance to RTD Curves: 0.15% max.

Repeatability: ±0.005% max., ±0.002% typ.

$$\text{Zero TC: } \pm \left(\frac{0.05}{\text{input span (ohms)}} + 0.005 \right) \% \text{ of span } ^\circ\text{C max.}$$

Span TC: ±0.008% of span max/°C

Load Effect: ±0.005% zero to full load

Output Ripple: 10 mV P/P maximum

Response Time: 110 milliseconds (10 to 90% step response)

Bandwidth: (-3 db): 3.2 Hz

Temperature Range:

-25° to 185°F (-31° to 85°C) operating;

-40° to 200°F (-40° to 93°C) storage

Power Supply Effect: ±0.005% of span, max.

Note: All accuracies are given as a % of span.

Power

15 to 42 VDC: 28 mA typical; 33 mA maximum

Mechanical

Electrical Classification: General purpose

Connection: Screw, compression type, accepts up to 14 AWG

Controls: Two 16 position rotary switches for coarse zero and span control; two multiturn potentiometers for fine zero and span control and jumpers for RTD type, major range, input zero elevation and output selection

Mounting: DIN rails, Surface, snap-track, or NEMA 4 or 7

Weight: Net Unit: 4 oz. (115 grams);

Shipping: Nominal 7 oz. (200 grams)

Options

H 15 D, H 25 – H 30 Mounting
LPI 40 D Loop powered indicator

RTD Input RBT 372 (Isolated)

Input/Output

Input Signals

Resistance Bulb Sensor: 2,3, or 4 wire types
1 to 400 ohm Resistance Spans: Standard
Zero Suppression: Up to 100% of the major range selected in 16 divisions of the coarse zero adjustment switch.
Span: From 0-100% full scale switch selectable. The coarse span switch adds 16 divisions to each major range.
Lead Compensation: 1% maximum error, of differential lead resistance.

Output Signals: 4-20 mA DC; 0-20 mA DC; 0-10 mA DC; 0-1 mA DC; 1-5 VDC; 0-5 VDC; 0-10 VDC

Output Loop Drive Capability:

$$R(\text{ohm}) = \frac{(V \text{ supply}-5)1,000}{I \text{ out max. mA}}$$

V Supply: 15 to 42 VDC

I out	4-20 mA or 0-20 mA			
V supply	15	24	36	42
R(ohms)	500	950	1550	1850

Performance

Calibrated Accuracy: $\pm 0.1\%$
Independent Linearity: $\pm 0.025\%$ max., $\pm 0.01\%$ typical
Conformance to RTD Curves: 0.15% max.
Repeatability: $\pm 0.005\%$ max., $\pm 0.002\%$ typ.
Zero TC: $\pm \left(\frac{0.05}{\text{input span (ohms)}} + 0.005 \right)$ % of span/ $^{\circ}\text{C}$ max.
Span TC: $\pm 0.008\%$ of span max./ $^{\circ}\text{C}$
Load Effect: $\pm 0.005\%$ zero to full load
Output Ripple: 10 mV P/P maximum
Response Time: 110 milliseconds (10 to 90% step response)
Bandwidth: (-3 db): 3.2 Hz
Temperature Range:
-25° to 185°F (-31° to 85°C) operating;
-40° to 200°F (-40° to 93°C) storage
Power Supply Effect: $\pm 0.005\%$ of span, max.
Isolation: Input/output/case: 1000VDC, or 600 VAC
Note: All accuracies are given as a % of span.

Power

15 to 42 VDC: 28 mA typical; 33 mA maximum

Mechanical

Electrical Classification: General purpose
Connection: Screw, compression type, accepts up to 14 AWG
Controls: Two 16 position rotary switches for coarse zero and span control; two multiturn potentiometers for fine zero and span control and jumpers for RTD type, major range, input zero elevation and output selection
Mounting: DIN rails, Surface, snap-track, or NEMA 4 or 7
Weight: Net Unit: 4 oz. (115 grams);
Shipping: Nominal 7 oz. (200 grams)

Options

H 15 D, H 25 - H 30 Mounting
LPI 40 D Loop powered indicator

I/V/MV Input SCT 302 (Isolated)

Input/Output

Input Signals

4-20 mA DC (z in 10 ohms)
0-20 or ± 20 mA DC (z in 10 ohms)
0-10 or ± 10 mA DC (z in 20 ohms)
0-1 or ± 1 mA DC (z in 200 ohms)
1-5 VDC (z in 1 megohm)
0-5 or ± 5 VDC (z in 1 megohm)
0-10 or ± 10 VDC (z in 1 megohm)
Any unipolar or bipolar voltage from 100 MV to 200 VDC (option I 14).
Zero Suppression: $\pm 10\%$
Span Adjustment: $\pm 10\%$

Output Signals: 4-20 mA DC; 0-20 mA DC; 0-10 mA DC; 0-1 mA DC; 1-5 VDC; 0-5 VDC; 0-10 VDC

Output Loop Drive Capability:

$$R(\text{ohm}) = \frac{(V \text{ supply}-5)1,000}{I \text{ out max. mA}}$$

V Supply: 15 to 42 VDC

I out	4-20 mA or 0-20 mA			
V supply	15	24	36	42
R(ohms)	500	950	1550	1850

Performance

Calibrated Accuracy: $\pm 0.1\%$
Independent Linearity: $\pm 0.025\%$ max., $\pm 0.01\%$ typical
Repeatability: $\pm 0.005\%$ max., $\pm 0.002\%$ typ.
Zero TC: $\pm 0.007\%$ of span max./ $^{\circ}\text{C}$
Span TC: $\pm 0.008\%$ of span max./ $^{\circ}\text{C}$
Load Effect: $\pm 0.005\%$ zero to full load
Output Ripple: 10 mV P/P maximum
Response Time: 110 milliseconds (10 to 90% step response)
Bandwidth: (-3 db): 3.2 Hz
Temperature Range:
-25° to 185°F (-31° to 85°C) operating;
-40° to 200°F (-40° to 93°C) storage
Power Supply Effect: $\pm 0.005\%$ of span, max.
Isolation: Input/output/case: 1000 VDC or 600 VAC
Note: All accuracies are given as a % of span.

Power

15 to 42 VDC: 28 mA typical; 33 mA maximum

Mechanical

Electrical Classification: General purpose
Connection: Screw, compression type, accepts up to 14 AWG
Controls: 8 jumpers for ranges; two multiturn potentiometers for zero, span
Mounting: DIN rails, Surface, snap-track, or NEMA 4 or 7
Weight: Net Unit: 4 oz. (115 grams);
Shipping: Nominal 7 oz. (200 grams)

Options

H 15 D, H 25 - H 30 Mounting
LPI 40 D Loop powered indicator

T/C Input TCT 326 (Isolated)

Input/Output

Input Signals

Thermocouple: All standard ISA calibration (B, E, J, K, R, S, T), -20 mV to 100 mV spans (Z in greater than 1 megohm)
Zero Suppression: Up to 100% of the major range selected in 16 divisions of the coarse zero adjustment switch.
Span: From 0.5 mV to 100 mV full scale switch selectable. The coarse span switch adds 16 divisions to each major range.
Upscale/Downscale Burnout Protection: Standard, field selectable
Burnout Current: 0.1 micro amperes—nominal
*Consult factory for other T/C types

Output Signals: 4-20 mA DC; 0-20 mA DC; 0-10 mA DC; 0-1 mA DC; 1-5 VDC; 0-5 VDC; 0-10 or ± 10 VDC

Output Loop Drive Capability:

$$R(\text{ohm}) = \frac{(V \text{ supply}-5)1,000}{I \text{ out max. mA}}$$

V Supply: 15 to 42 VDC

I out	4-20 mA or 0-20 mA			
V supply	15	24	36	42
R(ohms)	500	950	1550	1850

Performance

Calibrated Accuracy: $\pm 0.1\%$ (of mv input)
Independent Linearity: $\pm 0.01\%$ max., $\pm 0.006\%$ typical (14-bit digital linearity) (of millivolt input)
Repeatability: $\pm 0.005\%$ max., $\pm 0.002\%$ typ.
Zero TC: $\pm \left(\frac{0.025}{\text{input span (MV)}} + 0.007 \right)$ % of span/ $^{\circ}\text{C}$ max.
Span TC: $\pm 0.008\%$ of span max./ $^{\circ}\text{C}$
Load Effect: $\pm 0.005\%$ zero to full load
Output Ripple: 10 mV P/P maximum
Response Time: 110 milliseconds (10 to 90% step response)
Bandwidth: (-3 db): 3.2 Hz
Temperature Range:
-25° to 185°F (-31° to 85°C) operating;
-40° to 200°F (-40° to 93°C) storage
Power Supply Effect: $\pm 0.005\%$ of span, max.
Isolation: Input/output/case, 1000 VDC, or 600 VAC
Cold Junction Compensation Error: 1.5°C max (0 to 50°C)
Note: All accuracies are given as a % of span.

Power

15 to 42 VDC: 28 mA typical; 33 mA maximum

Mechanical

Electrical Classification: General purpose
Connection: Screw, compression type, accepts up to 14 AWG
Controls: Two 16 position rotary switches for coarse zero and span control; two multiturn potentiometers for fine zero and span control and jumpers for T/C type major range; input zero elevation and output selection
Mounting: DIN rails, Surface, snap-track, or NEMA 4 or 7
Weight: Net Unit: 4 oz. (115 grams);
Shipping: Nominal 7 oz. (200 grams)

Options

H 15 D, H 25 - H 30 Mounting
LPI 40 D Loop powered indicator

The ADTECH 300 Series Three-Wire Transmitters provide mounting efficiency and ease of wiring in a compact DIN package. Their small size makes them ideal replacements for the typical powered transmitter.

The units convert most sensor inputs to industry standard 4-20 mA, 1-5 VDC, 0-5 VDC or 0-10 VDC output for interface directly with PLC's, DCS's and process computers.

Most units provide independent linearity equivalent to 14-bit digital accuracy and include user friendly features such as wide ranging and non-interactive zero and span controls.

The compact DIN mounting style allows high density mounting in new or existing control panel enclosures or field mounted.

Standard mounting is DIN Rail. Surface or snap track mounting is provided at no charge. NEMA 4 or 7 are optionally available.

These units are designed for industrial environments. The housing is made of rugged Krilen for protection against corrosion, moisture and dust. Screw compression terminals are provided for positive field connections.

Reverse polarity protection is supplied as standard.

The power range of 15 to 42 VDC; 28 mA typical provides valuable added drive capability.

The input/output can be factory set to order as specified (no charge) or reconfigured in the field by simply adjusting switches, multi-turn potentiometers, and plug-in jumpers.

Integral LCD field indicator (LPI 40D) is optionally available.

AC to DC or DC to DC instrument power supplies are available. The IPS 2402 AC/DC powers up to 2 units. The IPS 2416 AC/DC or DC/DC powers up to 12 units. DIN, surface, snap track or NEMA mountings are available.

Connections

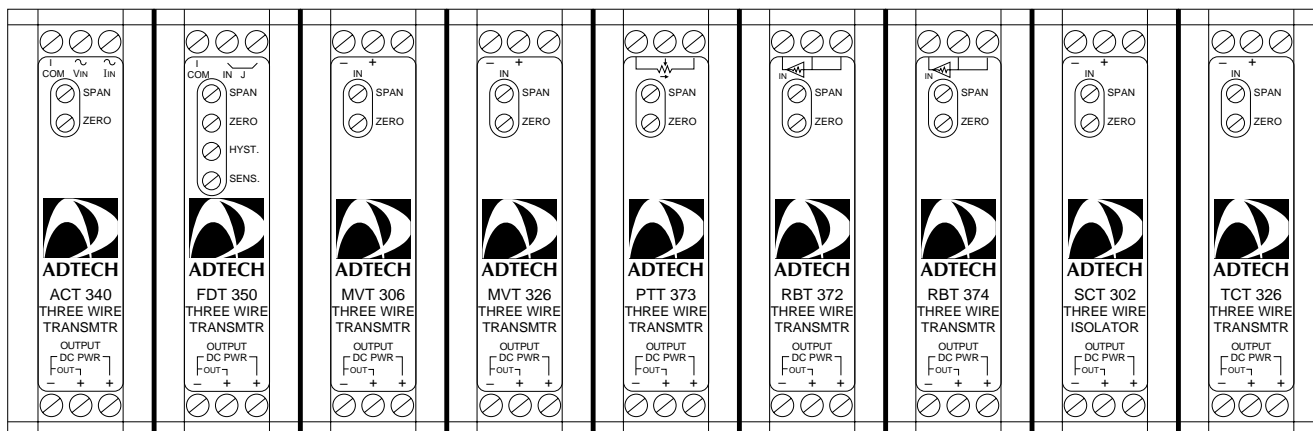

Typical Connection

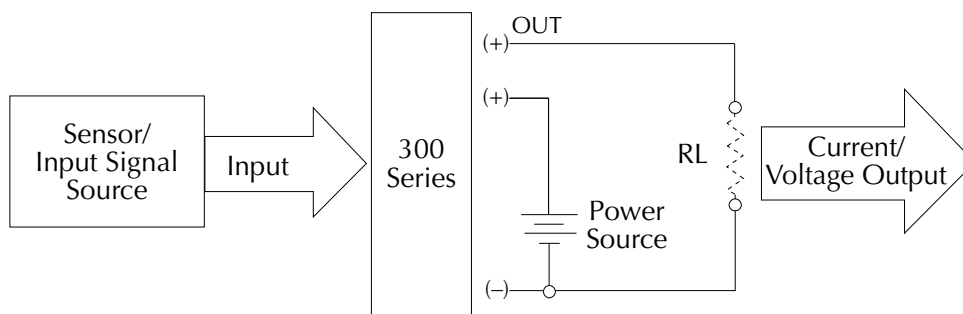

Outline & Mounting

DIN Mount (Standard)

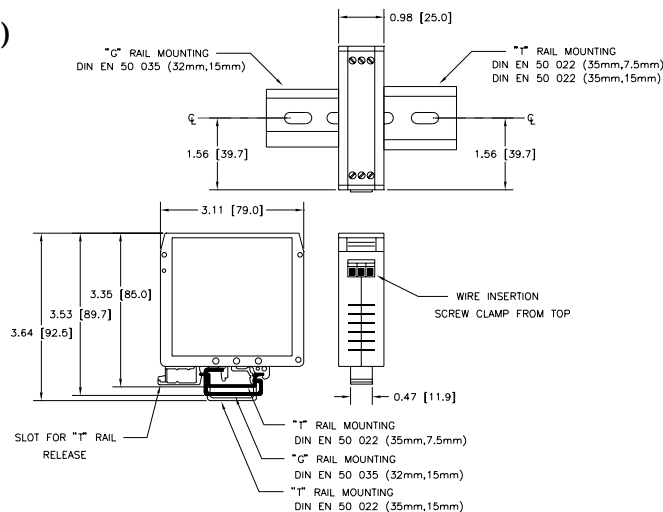

Snap Track Option H 25

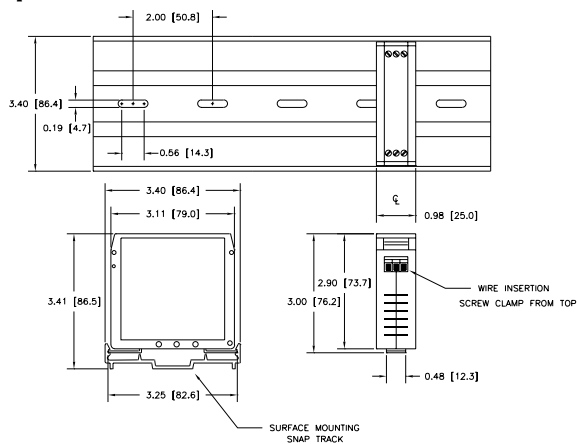

Surface Option H 26

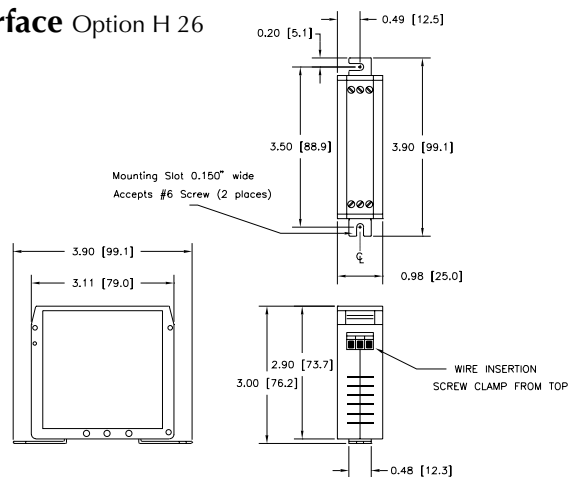

NEMA 4 Option H 27

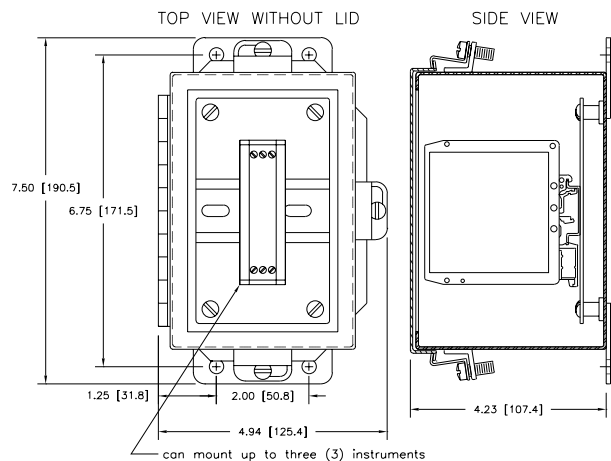

NEMA 7 Option H15D

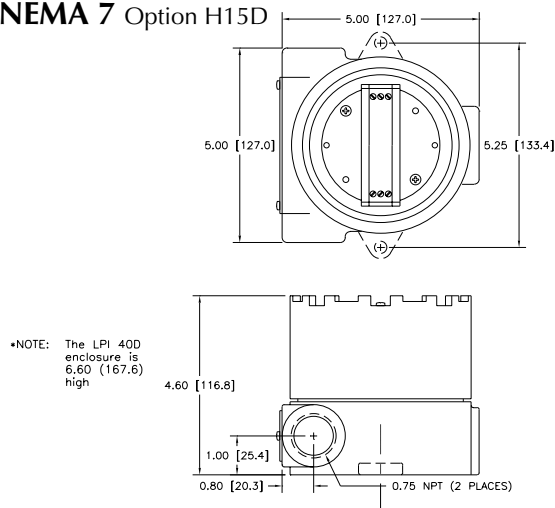

Represented by:



Analog-Digital Technology, Inc.
830 Canning Parkway
Victor, New York 14564-8940

Phone: (585) 869-6330
Fax: (585) 869-1835

E Mail: adtech@adtech-inst.com
Web site: <http://www.adtech-inst.com>

Information subject to change without notice.

Printed in U.S.A. A003