



ADTECH
Analog-Digital Technology, Inc.

The Adtech Model ECT 302 DC powered Isolated Signal Converter provides a user configurable solution for ground loops and problems encountered in connecting together recorders, process control systems, computers, DCS and PLC systems.

It is highly useful for applications that require signal isolation to eliminate ground loops, instrumentation level shifts, or the conditioning of a process signal riding over high common mode AC or DC voltages. Another common application is to provide additional amplification or drive to a process signal loop.

The ECT 302 breaks the galvanic path with 600 VAC/1,000 VDC input to output isolation between the transmitted signal and the output receiving device, insuring reliable and accurate signal transfer. Output signal negative and power negative are common.

It delivers standard process current or voltage signals on the output with a maximum of 10 mV P/P output ripple. This provides convenient interfacing of process signals to a computer system or other process instrumentation for improved resolution.

Zero and span controls are provided by two separate infinite resolution potentiometers. Recalibration to other ranges in the field is easy and convenient.

Din mounting is supplied as standard. Surface mount (option H 26) and snap track (option H 25) are available at no extra cost, specify.

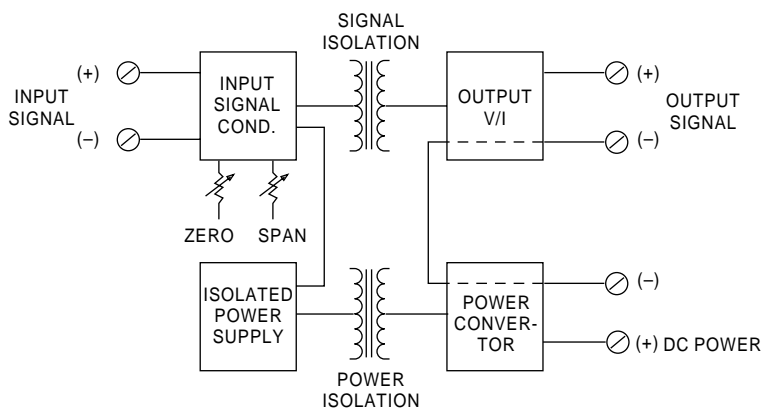

Features

- **DC Current Input:** 1 mA to 20 mA DC: (e.g. 4-20 mA DC)
- **DC Voltage Inputs:** 100 mV to 10 VDC: (e.g. 1-5 VDC)
- **Unipolar Inputs:** Current or voltage
- **Unipolar DC Process Signal Outputs:** Current or voltage
- **Repeatability:** $\pm 0.02\%$ of span typical
- **High Accuracy:** $\pm 0.1\%$ of span
- **Power:** 24 VDC

ECONOMY Isolated Signal Converter DC Powered

Model No. ECT 302

Typical Applications

- **Interface unequal or non-compatible plant ground systems**
- **Interface non-compatible instruments**
- **DCS-PLC-PC-MC Interface**
- **Isolate interference on signal lines**
- **Impedance conversion**



Connections/Dimensions

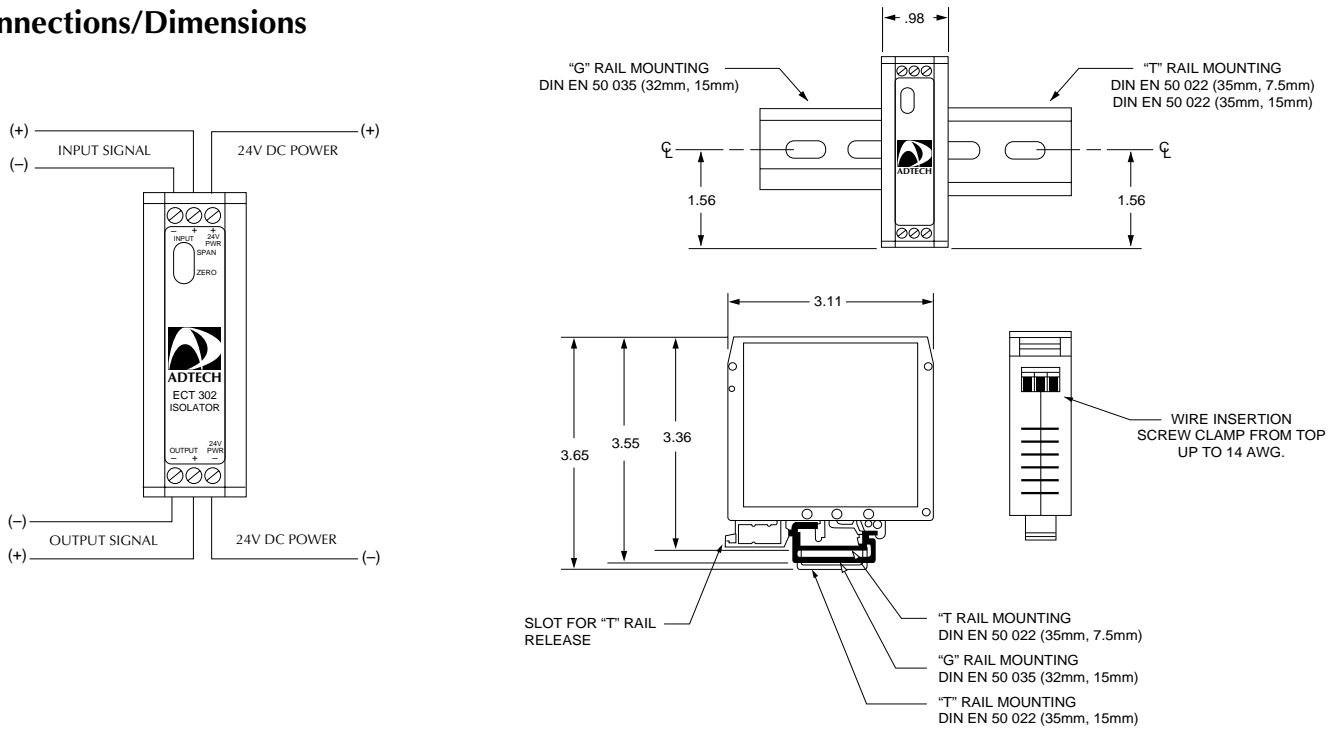

Input/Output

Input Signals: Jumper Configurable
 4-20 mA DC (Z in 10 ohms)
 0-20 mA DC (Z in 10 ohms)
 1-5 VDC (Z in 1 megohm)
 1-5 VDC (Z in 1 megohm)

Input Signals: Alterable
 0-1 mA DC (Z in 200 ohms)
 0-10 mA DC (Z in 20 ohms)
 0-10 VDC (Z in 1 megohm)

Output Signals: Jumper Configurable
 4-20 mA DC 0-900 ohms max.
 0-20 mA DC 0-900 ohms max.
 1-5 VDC 250k ohms min.
 0-5 VDC 250k ohms min.

Output Signals: Alterable
 0-1 mA DC 20k ohms max.
 0-10 mA 1800 ohms max.
 0-10 VDC 500k ohms min.

Performance

Calibrated Accuracy: $\pm 0.1\%$
Linearity: $\pm 0.1\%$ max., $\pm 0.04\%$ typical
Repeatability: $\pm 0.05\%$ maximum
Temperature Stability: $\pm 0.01\%/^{\circ}\text{F}$ max.,
 $\pm 0.004\%/^{\circ}\text{F}$ typical
Load Effect: $\pm 0.01\%$ zero to full load
Output Ripple: 10 mV P/P maximum
Response Time: 150 milliseconds
Bandwidth: (-3db) 2.3 Hz

Temperature Range:
 0° to 140°F (-18°C to 60°C) operating;
 -40° to -185°F (-40°C to 85°C) storage
Power Supply Effect: $\pm 0.05\%$ for
 $\pm 10\%$ power variation
Common Mode Rejection: 100 db @ 60 Hz
Isolation: Input/output/power 600 VAC, 50/60 Hz,
 1,000 VDC

Note: All accuracies are given as a percentage of span.

Power Mechanical

24 VDC, $\pm 10\%$, 1 watt maximum.

Electrical Classification: General purpose
Connection: Screw compression type
 accepts up to 14 AWG
Controls: Multiturn zero and span controls
 and jumpers for ranges

Mounting: DIN: Optional surface, snap track or
 Nema 4 & 7.
Weight: Net unit: 4.0 oz. (115 grams)
 Shipping: 7.0 oz. (200 grams)

Options

Option Number	Description
H 15D	Explosion Proof: Class 1, Group B,C & D
H 25	Snap-Track Mount (Specify)
H 26	Surface Mounting (Specify)
H 27	NEMA 4 Enclosure
H 29	T 35 DIN "T" rail two feet long
H 30	T 32 DIN "G" rail two feet long

Ordering Information

- Model number
- Input signal
- Output signal
- Housing and miscellaneous options

Please refer to the Housing and/or Option Section for more specific and detailed information.

Represented by:



Analog-Digital Technology, Inc.
 3750 Monroe Avenue
 Pittsford, New York 14534-1302
 Phone: (716) 383-8280
 Fax: (716) 383-8386
 E Mail: adtech@adtech-inst.com
 Web site: http://www.adtech-inst.com